

Item	Qty.	Description
1	2	Base Plate
2/2A	1/1	47.75" S80 Vertical Extrusion
3/3A	1/1	47.75" S80 Vertical Extrusion
4/4A	1/1	42.847" Z45 Horizontal Extrusion
5/5A	1/1	42.847" Z45 Horizontal Extrusion

Steps:

- 1) Attach base plates to verticals [2] and [3], using bolts.
- 2) Connect verticals [2] to [2A] and [3] to [3A].
See **V7 Connector** detail.
- 3) Connect horizontals [4] to [4A] and [5] to [5A].
See **PR53 Connector** detail.
- 4) Attach horizontal assemblies [4/4A] [5/5A] between vertical assemblies [2/2A] [3/3A].
See **Cam Lock Connector** detail.
- 5) Apply pillowcase fabric over assembled frame then zip closed.

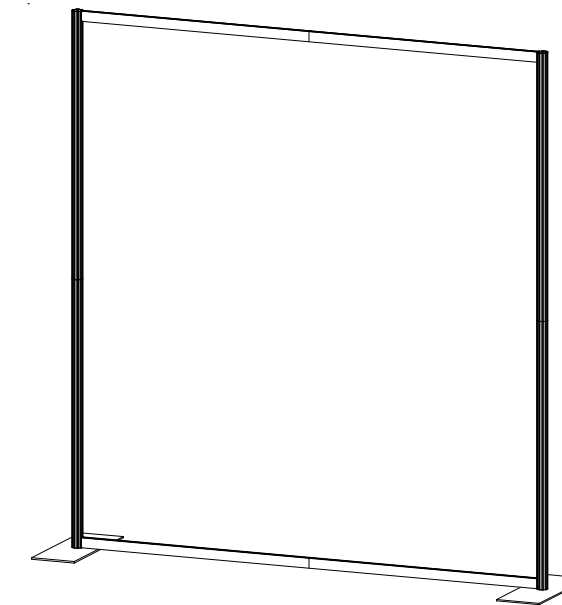

Completed Assembly

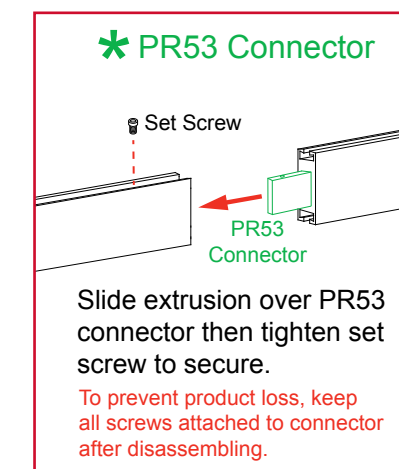
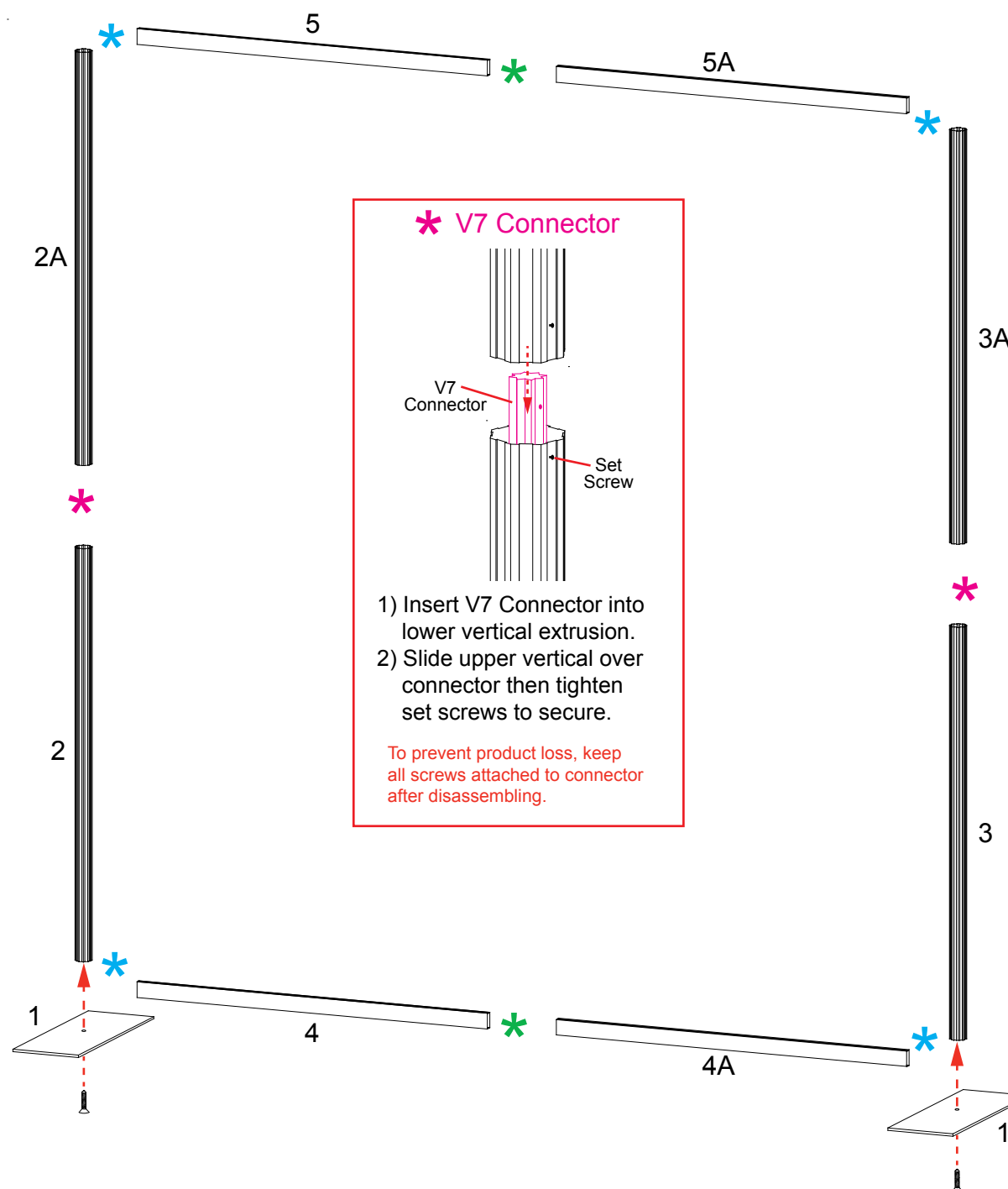
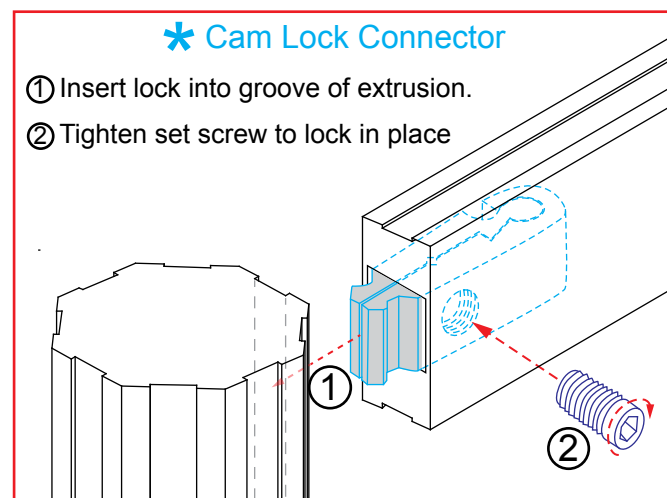

SETUP INSTRUCTIONS

General Setup Instructions

- Read entire setup instruction manual prior to unpacking parts and pieces.
- The setup instructions are created specifically for this configuration.
- Setup instructions are laid out sequentially in steps, including exploded views with detailed explanation for assembly.

Cleaning & Packing

- For Cleaning Metal, Plex, & Laminate Parts: Use a **MILD NON-ABRASIVE** cleanser and soft cloth/paper towel to clean all surfaces.
- Keep exhibit components away from heat and prolonged sun exposure.
Heat and UV exposure will warp and fade components.
- Retain all provided Packing Materials. All provided packing materials are for ease of repacking & component protection.

Disassembly

- For loss prevention, tighten all setscrews and locks during disassembly

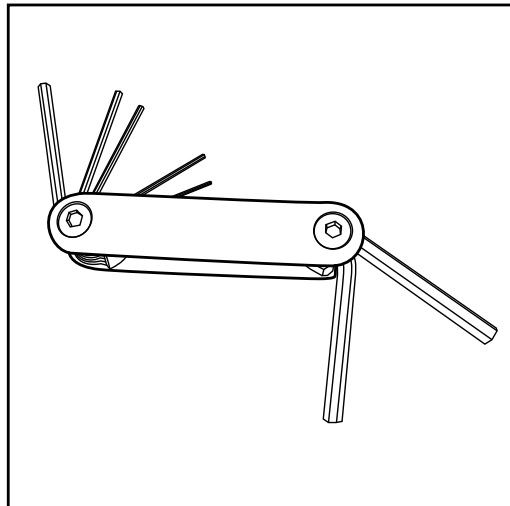

Hex Tool - Essential for Assembly

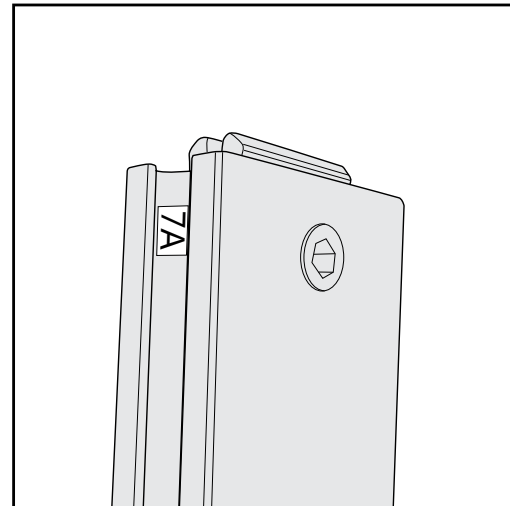

Part Identification - Numbering

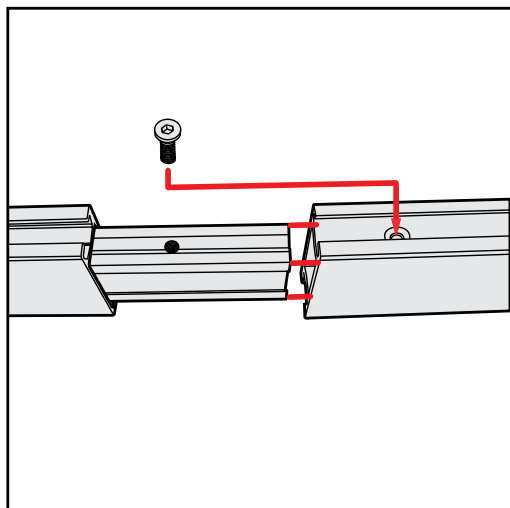

Spline Connection

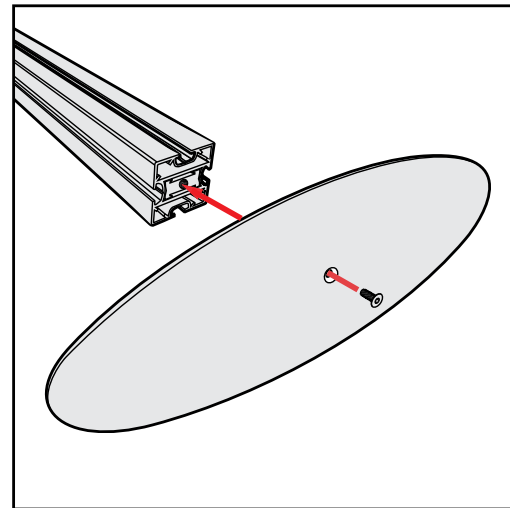

Base Plate & Extrusion Connection

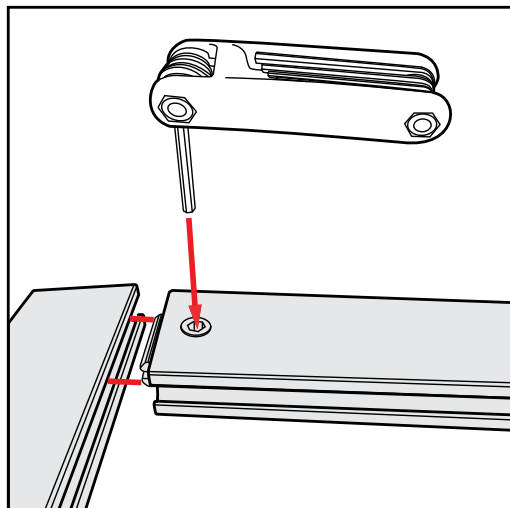

Extrusion & Lock Connection

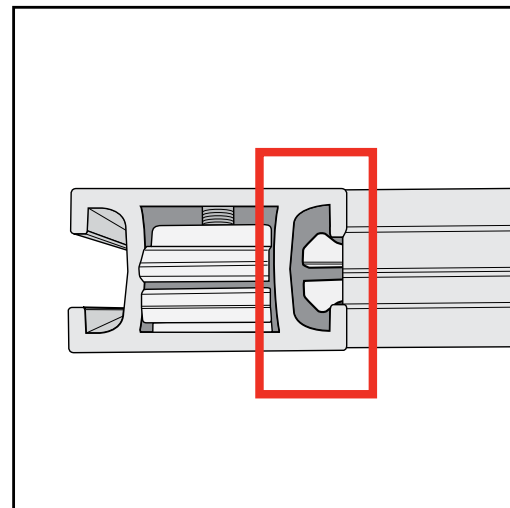

Engaged Lock



WARNING

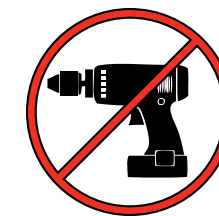

DO NOT USE POWER TOOLS



LADDERS OR LIFTS
MAY BE REQUIRED



ALL CONNECTIONS MUST
BE TIGHTLY SECURED

Top View of Each Level

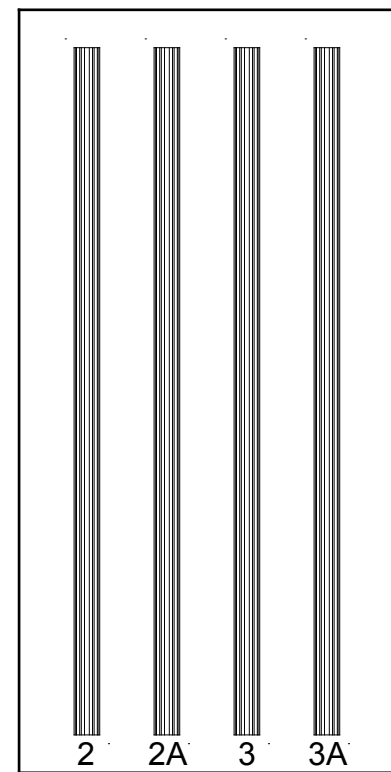

Level 1

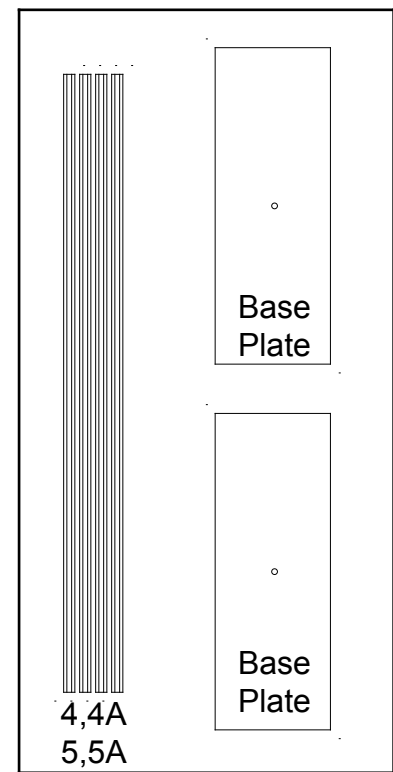

Level 2

